



**GIKI INSTITUTE OF ENGINEERING SCIENCES AND TECHNOLOGY, TOPI  
(PROCUREMENT DEPARTMENT)**

**SCHEDULE OF REQUIREMENTS FOR SUPPLY, INSTALLATION, COMMISSIONING,  
TESTING AND TRAINING OF EQUIPMENT FOR ROBOTICS & AUTOMATION LAB**

The delivery of services and supply will be made in 120 days after issuance of Purchase Order (without penalty) and with the prescribed penalty as per following schedule of requirement: -

MODE OF PENALTY	NO OF DAYS	TOTAL DELIVERY PERIOD
Without Penalty	120 days	120 days
With Penalty @ 0.10 % per day for 10 days, 0.15% per day for 20 days, 0.20% per day for 30 days, 0.25% per day after 30 days.		

**PRICE SCHEDULE FOR THE GOODS IN PAK RUPEES:**

Name of Bidder: \_\_\_\_\_

**Tender No: GIKI/PD/FME-FEE-989/23**

Supply, Installation, Commissioning, Testing and Training of Equipment for Robotics & Automation  
Lab

- tabulated as under:

Tender No.	Sr. No.	Description/Specification	Unit Price (RS)	Unit Price with 17% GST (RS)	Total Cost including GST (RS)	Bid Security (2% of the Total Cost)
GIKI/PD/FME-FEE-989/23	1	SUPPLY, INSTALLATION, COMMISSIONING, TESTING AND TRAINING OF EQUIPMENT FOR ROBOTICS & AUTOMATION LAB  (Details mentioned in Annex-A)				

Issued by: Deputy Director Procurement  
Signature of the Bidder: \_\_\_\_\_

Stamp of Bidder: \_\_\_\_\_

Note: In case of discrepancy between unit price and total, the unit price shall prevail.

# SPECIFICATIONS

## TENDER NO. (GIKI/PD/FME-FEE-989/23)

### SUPPLY, INSTALLATION, COMMISSIONING, TESTING AND TRAINING OF EQUIPMENT FOR ROBOTICS & AUTOMATION LAB

#### 1) Universal Robots, UR5E or equivalent latest edition (Qty. 01)

Payload: 5 Kg, Reach: 850mm, including all accessories such as Fixed Cobot base, control box, teach pendant, software etc.

#### Specifications:

Specification		
Payload	5 kg (11 lbs)	
Reach	850 mm (33.5 in)	
Degrees of freedom	6 rotating joints	
Programming	12 inch touchscreen with polyscope graphical user interface	
Performance		
Power, Consumption, Maximum Average	570 W	
Power, Consumption, Typical with moderate settings (approximate)	200 W	
Safety	17 configurable safety functions	
Certifications	EN ISO 13849-1, PLd Category 3, and EN ISO 10218-1	
Force Sensing, Tool Flange	Force, x-y-z	Torque, x-y-z
Range	50.0 N	10.0 Nm
Precision	3.5 N	0.2 Nm
Accuracy	4.0 N	0.3 Nm
Movement		
Pose Repeatability per ISO 9283	± 0.03 mm	
Axis movement	Working range	Maximum speed
Base	± 360°	± 180°/s
Shoulder	± 360°	± 180°/s
Elbow	± 360°	± 180°/s
Wrist 1	± 360°	± 180°/s
Wrist 2	± 360°	± 180°/s
Wrist 3	± 360°	± 180°/s
Typical TCP speed	1 m/s (39.4 in/s)	
Features		
IP classification	IP54	
ISO 14644-1 Class Cleanroom	5	
Noise	Less than 65 dB(A)	
Robot mounting	Any orientation	
I/O ports		
Digital in	2	
Digital out	2	
Analog in	2	
Tool I/O Power Supply Voltage	12/24 V	
Tool I/O Power Supply	1.5 A (Dual pin) 1 A (Single pin)	
Physical		
Footprint	Ø 149 mm	
Materials	Aluminium, Plastic, Steel	
Tool (end-effector) connector type	M8   M8 8-pin	
Cable length robot arm	6 m (236 in) cable included. 12 m (472 in) and high-flex options available.	
Weight including cable	20.6 kg (45.4 lbs)	
Operating temperature range	0-50°C	
Humidity	98%RH (non-condensing)	



Control Box	
Features	
IP classification	IP44
ISO 14644-1 Class Cleanroom	6
Operating temperature range	0-50°C
Humidity	98%RH (non-condensing)
I/O ports	
Digital in	16
Digital out	16
Analog in	2
Analog out	2
Quadrature Digital Inputs	4
I/O Power Supply	24V 2A
Communication	500 Hz Control frequency Modbus TCP PROFINET Ethernet/IP USB 2.0, USB 3.0
Power source	100-240VAC, 47-440Hz
Physical	
Control box size (W x H x D)	460 mm x 449 mm x 254 mm (18.2 in x 17.6 in x 10 in)
Weight	12 kg (26.5 lbs)
Materials	Powder Coated Steel
<i>The control box is also available in an OEM version.</i>	
Teach Pendant	
Features	
IP classification	IP54
Humidity	98%RH (non-condensing)
Display resolution	1280 x 800 pixels
Physical	
Materials	Plastic, PP
Weight	1.6 kg (3.5 lbs) including 1m of TP cable
Cable length	4.5 m (177.17 in)

**2. Robot gripper(s) compatible with UR5E robot or equivalent. (Qty. 01)**  
 Robotiq, 2F-85 or equivalent

**Specifications:**

SPECIFICATIONS	2F-85
Stroke (adjustable)	85 mm
Grip force (adjustable)	20 to 235 N
Form-fit grip payload	5 kg
Friction grip payload	5 kg
Gripper mass	0.9 kg
Position resolution (fingertip)	0.4 mm
Closing speed (adjustable)	20 to 150 mm/s
Communication protocol	Modbus RT
Ingress protection (IP) rating	IP40

**3. Robotic hand, QB Robotics and Soft Hand Research compatible with UR5E or equivalent (Qty. 01)**

technical data

MECHANICAL	UNIT	NOMINAL	MIN	MAX
weight	[kg]	0.77	—	—
joints	[#]	19	—	—
motor	[#]	1	—	—
power grasp payload	[kg]	—	—	2.1
pinch grasp payload	[kg]	—	—	1.1
hanging payload	[kg]	—	—	5.0
full closing time	[s]	—	—	1.1

INERTIAL*	UNIT	X	Y	Z
center of mass, open	[mm]	2.7	82.9	-0.5
center of mass, closed	[mm]	1.3	76.6	3.5

\* all values refer to the right version, minus the x value for the left one

RESILIENCE	UNIT	1-FINGER	4-FINGER	5-FINGER
impact energy	[J]	98	98	19
impact speed	[m/s]	4.7	4.7	—
impact force	[N]	—	—	200

ENVIRONMENTAL	UNIT	NOMINAL	MIN	MAX
operating temperature	[°C]	20	-5	50
storage temperature	[°C]	—	-20	50
noise level	[dB]	62	44	72

ELECTRICAL	UNIT	NOMINAL	MIN	MAX
operating voltage	[V]	24	23.1	24.8
power consumption	[W]	18	1.4	30

CONTROL  
 communication protocol: RS485

FEATURES  
 plug-and-play  
 soft, human-like fingers  
 right and left versions  
 different cover colours

NORMATIVE COMPLIANCE		
ISO 9409-1-31.5-4-M5	ISO 9409-1-40-4-M6	
ISO 9409-1-50-4-M6		

additional technical data

FINGERS WORKSPACE

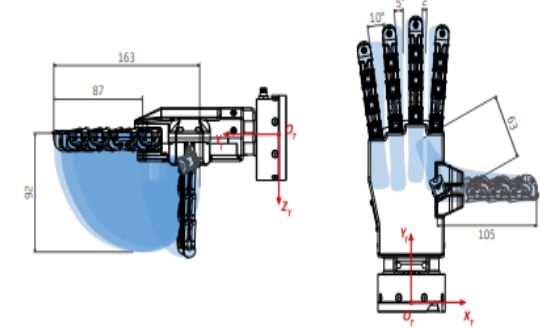

KINEMATICS

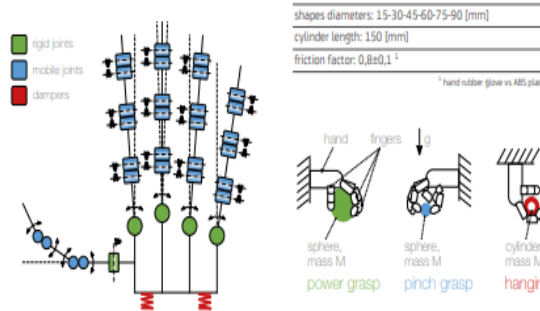
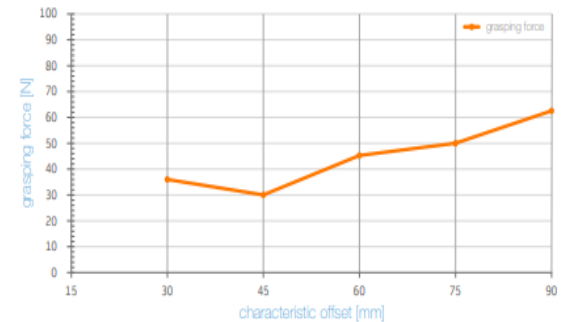

CHART NOTES

shapes diameters: 15-30-45-60-75-90 [mm]  
 cylinder length: 150 [mm]  
 friction factor:  $0.8 \pm 0.1$   
 \*hand rubber glove vs ABS plastics

The table gives the coordinates of the product, it does not represent an approximation of the technical characteristics of the product as represented in Satec's catalogues, price lists, advertisements or any other publications that will be considered as part of our website.

MAXIMUM GRASPING FORCE CHART\*



MAXIMUM PAYLOAD CHART

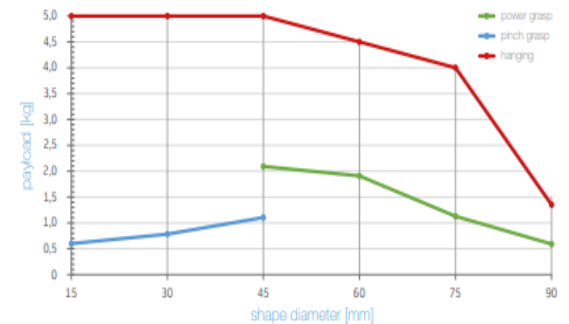

ELECTRICAL CONNECTIONS

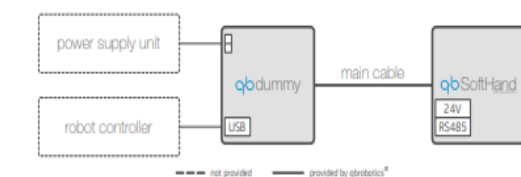

CONNECTOR PIN-OUT

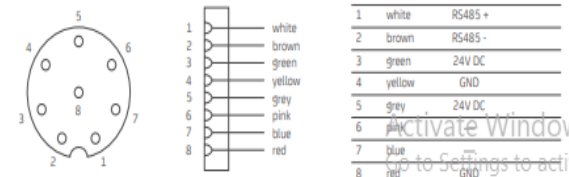

**4. DOBOT magician educational model Robotic arm or equivalent including all accessories such as:**

- i. Robot Arm
- ii. Vacuum Pump Kit,
- iii. Gripper,
- iv. Writing and Drawing Kit,
- v. 3D Printing Kit,
- vi. Bluetooth Module,
- vii. Laser Engraving Kit,
- viii. Wi-Fi Module,
- ix. Joystick Control Kit,
- x. AI starter,
- xi. Magician go including magic box controller,
- xii. Dobot Magician lite includes end tools.
- xiii. Dobot Conveyor Belt.

Please quote the price of each accessory separately (Qty.01 each)

## Specifications:

DOBOT or equivalent magician educational model Robotic arm including (i. Robot Arm ii. Vacuum Pump Kit, iii. Gripper, iv. Writing and Drawing Kit, v. 3D Printing Kit, vi. Bluetooth Module, vii. Laser Engraving Kit, viii. Wi-Fi Module, ix. Joystick Control Kit).



### Robot Arm

Robot Arm

### Power Adapter / USB Cable

Voedingsadapter / USB-kabel

### Masking Tape (3d Printing)

Afplaktape (3D printen)

### Feed Pipe (3d Printing)

Toevoerleiding (3D printen)

### Accessories

Accessoires

- Shipping list
- Quick Start
- Glass Plate (3d Printing)
- Sensor Calibration Board
- Kraft Linner Paper (3d Printing)

### Writing Drawing Kit

Schrijven tekenpakket

- Pen holder
- Pen

### Pneumatic Kit

Pneumatische set

- Pneumatic Gripper
- Suction Cup & Joint 4
- Air Pump Controller

### Tool Package

Gereedschapspakket

- Hexagon Screwdriver
- M1.5 M2 M2.5
- Quick Fix Screw
- Calibration Tool
- Jackscrew x2

### Bluetooth Module (Wireless-1)

Bluetooth-module (draadloos-1)

### WiFi Module (Wireless-2)

WiFi-module (draadloos-2)

### Joystick Control Kit

Joystick-bedienset

- USB Connector Host
- Joystick

### Laser Kit

Laserkit

- Laser Module
- Laser Protective Glasses

### 3D Printing Kit

3D-printkit

- Extruder
- Hot End
- 3D Printing Filament Holder
- Filament 200g

## X. AI starter,



### • Compatible with Arduino Mega 2560

Both Arduino related learning resources and Arduino IDE can be used.

### • Graphical Programming

Supports MIXLY graphical programming language

### • Various Sensor Modules

Line inspection sensor, ultrasonic sensor, color sensor, geomagnetic sensor, etc. Various expansion interfaces support external sensors.

### • One-Step Built-in Charging

Built-in charging function, online battery management, easy to operate

## **XI. Magician go,**



**Quick Start**  
Snelle start

**Bluetooth Dongle x1**  
Bluetooth-dongle x1

**AI Camera Kit x1**  
AI Camera Kit x1

**Power Box x2**  
Powerbox x2  
\*They have been built into  
the DOBOT Magician GO

**Magic Box x1**  
Magic Box x1

**DOBOT Magician GO x1**  
DOBOT Magician GO x1

**Camera Calibration Card x1**  
Camera Kalibratie Kaart x1

**Joystick Kit x1**  
Joystick Kit x1

- Joystick \*1
- USB Connector \*1
- Charging line of Joystick \*1

**Power Adapter x1**  
Voedingsadapter x1

**Accessory Kit x1**  
Accessoirekit x1

- 1.5 mm Allen wrench x 1
- 2.0 mm Allen wrench x 1
- 2.5 mm Allen wrench x 1
- M2\*25 Hexagon socket head screws x 2
- M3\*6 Hexagon socket head screws x 2
- M3\*8 Hexagon socket countersunk head screws x 2
- M2 Hexagon nuts x 2
- USB Cable x 1

## Xii Dobot Magician lite



### Magician Lite Magician Lite

#### Building block kit Bouwpakket kit

- Building blocks x 15
- Block pallet x 2

#### Work mat Werkmat

#### Tool kit Gereedschapskist

- 1.5 mm Allen wrench
- 2 mm Allen wrench
- Suction cup
- Set screw

#### End tools-Soft Gripper Eindgereedschap-Soft Gripper

Eindgereedschap-Soft Gripper

#### End tools-Pen Holder Eindgereedschap-Pen houder

Eindgereedschap-Pen houder

#### Ink Sac x 2 Inktzak x 2

Inktzak x 2

#### Cable set Kabelset

- 4Pin Power cable x 2
- 10Pin Communication cable
- USB cable

#### End tools-Suction Cup Eindgereedschap-Zuignap

\* Attached on the robot

#### Magic Box controller Magic Box Controller

Magic Box Controller

#### Power Box Powerbox

Powerbox

#### Power adapter Oplader

Oplader

#### Camera Kit

- Camera Kit
- Cable Clip

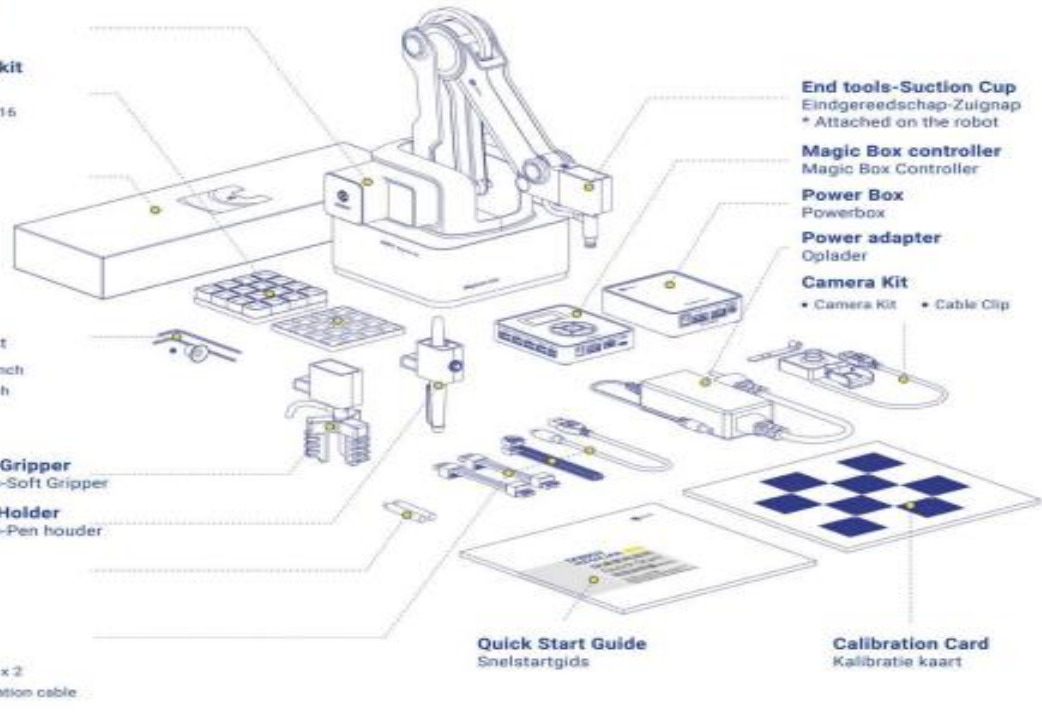

## Xiii: Conveyor Belt compatible with Dobot magician.

## Conveyor Belt



#### Specifications:

- Payload - 500 g
- Delivering distance - 600 mm
- Maximum speed - 120 mm/s
- Maximum acceleration - 1100 mm/s<sup>2</sup>
- Dimension - 700 mm x 215 mm x 60 mm
- Weight - 4.2kg

**5. Mobile robots, ClearPath robotics or equivalent (Qty. 01 each):**

- i. TurtleBot 4 standard with ROS support including software (compatible and/or equivalent).
- ii. TurtleBot lite with ROS support including software (compatible and/or equivalent).



	TurtleBot 4	TurtleBot 4 Lite
<b>SIZE AND WEIGHT</b>		
<b>EXTERNAL DIMENSIONS (LxWxH)</b>	341 x 339 x 351 mm (13.4 x 13.3 x 13.8 in)	341 x 339 x 192 mm (13.4 x 13.3 x 7.5 in)
<b>WEIGHT</b>	3.9 kg (8.6 lbs)	3.3 kg (7.2 lbs)
<b>WHEELS (Diameter)</b>	72 mm (0.55 in)	
<b>GROUND CLEARANCE</b>	4.5 mm (0.17 in)	
<b>SPEED AND PERFORMANCE</b>		
<b>MAX PAYLOAD</b>	9 Kg - Default 15 kg - Custom Configuration	
<b>MAX SPEED</b>	0.31 m/s (safe model), 0.46 m/s (cliff sensors disabled)	
<b>MAX ROTATIONAL SPEED</b>	1.90 rad/s	
<b>BATTERY AND POWER SYSTEM</b>		
<b>CHEMISTRY</b>	26 Wh Lithium Ion (14.4V nominal) Rechargeable	
<b>CHARGE TIME</b>	2.5 hrs	
<b>OPERATING TIME</b>	2.5 - 4.0 hrs (load dependent)	
<b>USER POWER</b>	VBAT @ 300mA, 12V @ TBD mA, 5V @ 500mA 3.3V @ 250mA	VBAT @ 1.9A (14.4V nominal) Low current 5V and 3.3V via Raspberry Pi GPIO
<b>DOCKING</b>	Base station for docked charging	
<b>SENSORS</b>		
<b>2D LIDAR</b>	<b>RPLIDAR-A1</b> 0.15-12m range; 8kHz sampling rate; 360 degree angular range; 1 degree angular resolution.	
<b>CAMERA</b>	<b>OAK-D-PRO</b> 4K RGB auto focus camera (IMX378) Mono stereo camera pair (OV9282) IMU, Spatial AI processor IR Laser Dot Projector & Illumination LED	<b>OAK-D-LITE</b> 4K RGB auto focus camera (IMX214) Mono stereo camera pair (OV251) Spatial AI processor
<b>OTHER SENSORS</b>	2x front bumper zones, 2x wheel encoders, 4x IR cliff sensors, 6x IR obstacle sensors, 1x downward optical flow sensor for odometry, 1x 3D gyroscope, 1x 3D accelerometer, 1x battery level monitor	
<b>OTHER ACTUATORS</b>	2x Drive Motors, 6x RGB LED Ring 1x Speaker, 5 Status LEDs 2 User LEDs, 128x64 OLED Display	2x Drive Motors, 6x RGB LED Ring 1x Speaker
<b>COMPUTERS</b>		
<b>COMPUTER</b>	Raspberry Pi 4B (4 GB)	
<b>SOFTWARE</b>	Ubuntu 20.04, ROS 2	

**6. Complete Robotic Lego kit 51515, Mindstorms or equivalent (Qty. 03)**

**7. RoboDK software or other equivalent and compatible software:** two-year subscription for educational use only: Version 5.6 or latest (Qty. 10)

**8. Desktop:** 12th Gen or higher Intel Core i9 or equivalent, RAM 32 GB, 1TB SSD, built in Wi-Fi, including all accessories such as keyboard, mouse, connectors, LCD 27" latest model compatible - **(Dell, HP or equivalent) (Qty. 04)**

**9. QUBE-Servo 2 USB (Qty. 04):**

Fully integrated, modular servomotor experiment for teaching mechatronics and controls. Includes: - QFLEX 2 USB Interface Panel - Built-in Amplifier - Inertia Disk and Pendulum modules - Other QFLEX 2 panels can be purchased separately - User Manual, Quick Start Guide, Instructor and Student Workbooks and pre-designed controllers. 9023.00.00 CA

**10. QUARC Essentials Software License (Qty.04)**

QUARC Essentials Platform provides flexible hardware interfacing and takes full advantage of Quanser's course resources to rapidly deploy an experiential teaching lab. QUARC is fully integrated with Matlab/Simulink and requires Matlab Coder and Simulink Coder for full operation. CA

**11. Encoded stepper motors, Motecmotor or equivalent**

***MT-1704HS200EC-1000***

***MT-2303HS280BM***

***or with equivalent specification (Qty. 03 for each model).***

Item	Specifications
Step Angle	1.8°
Step Angle Accuracy	1.8°±5% (full step, no load)
Resistance Accuracy	±10%
Inductance Accuracy	±20%
Temperature Rise	80°C Max.(2 phase on)
Ambient Temperature	-20°C~+50°C
Insulation Class	B, 130°C
Insulation Resistance	100MΩMin. , 500VDC
Shaft Radial Play	0.02Max. (450 g-load)
Shaft Axial Play	0.08Max. (450 g-load)
Max. radial force	28N (20mm from the flange)
Max. axial force	10N

Dimension (Length "L1" mm)	Model # Single Shaft	Rated Current (Amps/Phase)	Holding Torque (oz.in)	Holding Torque (kg.cm)	Resistance (Ohms/Phase)	Inductance (mH/Phase)	Inertia (g.cm <sup>2</sup> )	Resolution CPR	Speed Range RPM
48(L1)+20 (2.68")	MT-1704HS200EC-1000	2.00	83.3	6.0	1.4	3.0	68	1000	≤3000rpm

**Encoder Specs**

Driving Voltage	5V
Current Consumption	≤50mA
Output Current	0-5mA
Output Method	Output Differential (Line Driver Output), Two Channels
Response Frequency	0-20KHz
Working Tem.	-25°C-85°C
Working Humidity	30-85% (no condensation)
IP Protection	IP20



Item	Specifications
Step Angle	1.8°
Step Angle Accuracy	1.8°±5% (full step, no load)
Resistance Accuracy	±10%
Inductance Accuracy	±20%
Temperature Rise	80°C Max.(2 phase on)
Ambient Temperature	-20°C~+50°C
Insulation Class	B, 130°C
Insulation Resistance	100MΩMin. , 500VDC
Shaft Radial Play	0.02Max. (450 g-load)
Shaft Axial Play	0.08Max. (450 g-load)
Max. radial force	28N (20mm from the flange)
Max. axial force	10N

Model # Single Shaft	Rated Current (Amps/Phase)	Holding Torque (oz.in)	Holding Torque (kg.cm)	Resistance (Ohms/Phase)	Inductance (mH/Phase)	Inertia (g.cm <sup>2</sup> )	Detent Torque (g.cm)	Weight (kg)	Recommen Voltage (V DC)
MT- 2303HS280BM	2.80	175.0	12.6	0.9	2.5	300	400	0.74	24-48

## ENCODER

### · Feature

It has 3 square-wave outputs which are 90-degree phase shifted for counting and direction information and one optional index channel.

### · Specification

· Electrical Specifications	
Output Wave	Square Wave
Current Consumption	≤60mA
Output Current	0-5mA
Response Frequency	0-100KHz
Output Phase Difference	90°± 45°
Signal Level	V <sub>H</sub> ≥85%V <sub>CC</sub> , V <sub>L</sub> ≤0.3V

· Mechanical Specifications	
Rotor Inertia Of Code-Wheel	6.0x10 <sup>-8</sup> Kgm <sup>2</sup>
Shock Resistance	980m/s <sup>2</sup> , 6ms, 2 times each on XYZ
Vibration Proof	50m/s <sup>2</sup> , 10-200Hz, 2 hours each on XYZ
Working Life	MTBF≥50000h (+25°C, 2000rpm)
Weight	10g
· Environmental Specifications	
Working Humidity	30-85% (no condensation)
Working Tem.	-25°C-85°C
Storage Tem.	-40°C-85°C
Weld Tem.	≤260°C

**12. Stepper motor drivers, Leadshine or equivalent**

- i. DM556 Stepper Motor Driver
- ii. DM865Z Stepper Motor Driver

***or with equivalent specification (Qty. 03 for each model).***

**13. Dynamixel Servo motor or equivalent**

- i. Dynamixel AX-12
- ii. Dynamixel XL430-w250-T
- iii. Dynamixel XL330-M288-T
- iv. Dynamixel XL 320

***or with equivalent specification (Qty. 02 for each model).***

**14. Raspberry pi 4B Micro-controller, 4GB RAM, complete developer kit – Qty. 05**

**15. Jetson nano micro-controller, 4GB RAM, complete developer kit – Qty. 05**

**16. Lidar Sensor, Slamtec, Model. RP Lidar A2 sensor A2M12 or equivalent – Qty. 02**

Rotational Speed	10Hz(5Hz-15Hz)	 A2M12 16K 0.225°
Measuring Range	0.2m – 12m	
Scan Field Flatness	±1.5°	
Temperature Range	360°	
Proof Level	Class 1	
Weight	190g	
System Voltage	5V	
Temperature range	20°C-40°C	

**17. Intel real sense depth cams – Qty. 01 for each model**

- i. Intel® RealSense™ Depth Camera D435if
- ii. Intel® RealSense™ Depth Camera D457

***or with equivalent specification***

Deputy Director Procurement  
GIK Institute, Topi

## **TENDER BIDS SUBMISSION & OPENING DATE AND TIME**

**Supply, Installation, Commissioning, Testing and Training of Equipment for  
Robotics & Automation Lab**

### **TENDER NOTICE: GIKI/PD/FME-FEE-989/23**

<b>Tender No.</b>	<b>Description/Specification</b>	<b>Date of Submission of Tender Documents</b>	<b>Date Opening of Tender</b>
<b>GIKI/PD/FME-FEE-989/23</b>	<b>Supply, Installation, Commissioning, Testing and Training of Equipment for Robotics &amp; Automation Lab</b>	<b>1500 hours December 15, 2023</b>	<b>1530 hours December 15, 2023</b>

Deputy Director Procurement  
GIK Institute, Topi

## GIK INSTITUTE OF ENGINEERING SCIENCES AND TECHNOLOGY, TOPI

**Technical Evaluation Criteria:** The Bidders who have duly complied with the Eligibility / Qualification and Evaluation will be eligible for further processing. The Bids which do not conform to the Technical Specifications or Bid conditions or the Bids from the Bidders without adequate capabilities for supply and maintenance / warranty services will be rejected. The Eligible/Technically Qualified Bidders will be considered for further evaluation.

Technical Bids will be evaluated on the basis of following criteria and Financial Bids of only those bidders will be opened who have fulfilled the criteria:

<b>Evaluation Criteria</b>		<b>Requirement Mandatory</b>	
Sales Tax Registration			
Income Tax Registration			
Conformance to the required specification of items given in Schedule of Requirement			
At least two relevant Supply Orders/Contracts received in the last three years			
Affidavit /Bidder's Undertaking on stamp paper			
S. No.	Item Name and Description	Marks	Max. Marks
<b>1</b>	<b>Similar / Relevant Experience of the bidder</b>	--	<b>08</b>
1.1	1 – 5 Years' Experience	03	
1.2	5 – 10 Years' Experience	06	
1.3	Above 10 years' experience	08	
<b>2</b>	<b>Experience of the Technical Team in Installation, configuration of mentioned Products</b>	-	04
2.1	1 - 7 years' experience	02	--
2.2	07 & above year experience	04	--
<b>3</b>	<b>Financial Soundness of the bidder</b>	--	<b>06</b>
3.1	Bank Statement of last year showing cash flow between Rs. 5 million to Rs. 10 million	2	
3.2	Bank Statement of last year showing cash flow between Rs. 11 million to Rs. 20 million	4	
3.4	Undertaking for No Litigation History	2	
<b>4</b>	<b>Technical Evaluation of quoted items</b>	--	<b>52</b>
4.1	<b>Specification attached at Annex-A</b>	40	--
4.2	Delivery schedule as per requirement at our premises	1	--
4.3	Warranty Period (Min 1 year)	2	--
4.4	Installation, commissioning, testing & training free of cost	2	--
4.5	Provision of support / after sales services Minimum (1 year)	2	--
4.6	Certificate of Certified partner, Authorized Dealer / Distributer	2	
<b>5</b>	<b>Response time during warranty period for rectification of Fault</b>	--	<b>3</b>
5.1	Within 2 working days	3	--
5.2	Within 3 to 4 working days	1	--
<b>TOTAL</b>			<b>70</b>

**Note: Please submit documents as per above mentioned criteria**

- Technical qualification status shall be decided on the basis of Pass/Fail basis. The applicant must secure at least 70% score accumulative.
- Order/contract will be awarded on the basis of highest score considering 70% technical and 30% Financial.

Deputy Director Procurement  
GIK Institute, Topi

**GIK INSTITUTE OF ENGINEERING  
SCIENCES AND TECHNOLOGY, TOPI**

**TENDER NO.**

**GIKI/PD/FME-FEE-989/23**

**TENDER DOCUMENT**

**F.O.R BASIS**

**TENDER FEE NON-REFUNDABLE**

**Rs. 3,000/-**

**PROCUREMENT DEPARTMENT**

Ph: 0938-281026 EXT (2213) Fax: 0938-281045 Mobile: 0321-2428865

Email: [farid.wahid@giki.edu.pk](mailto:farid.wahid@giki.edu.pk)

Web: [www.giki.edu.pk](http://www.giki.edu.pk)

**GIK INSTITUTE OF ENGINEERING SCIENCES AND TECHNOLOGY, TOPI**  
**PROCUREMENT DEPARTMENT**

**INTRODUCTION:**

GIK INSTITUTE OF ENGINEERING SCIENCES AND TECHNOLOGY, TOPI, having (hereinafter referred to as the Purchaser) invites sealed bids from eligible bidder(s) under Single Stage Two envelop bidding system (i.e. Technical and Financial Bids in separate envelopes) for supply and delivery of goods, materials, equipment and/or services described in the Schedule of Requirement. All the Annexure from “C” to “L” are integral part of the Tender Document and its compliance is mandatory and must be signed and stamped by the vendor/supplier and attached with the relevant proposal, otherwise bids will be rejected.

The Technical Bids will be opened first on the date mentioned in the Tender Notice. The financial bids of the only technically qualified bidder(s) will be opened publicly. The Technical Evaluation Report will be published on GIK INSTITUTE, website before financial bid opening.

**1. INSTRUCTIONS TO BIDDER(S):**

- 1.1. The bidder(s) shall manufacture all machines according to the drawing and models and bring also samples and bear all cost associated with the preparation and delivery of their bids, and the Purchaser will in no case be responsible or liable for those costs.
- 1.2. In case of any doubt as to the meaning of any portion of the Specifications or other Terms and Conditions, bidder(s) may seek clarification of the same in writing, but not later than 5 days prior to deadline for submission of bid(s) prescribed by the Purchaser.
- 1.3. At any time prior to the deadline for submission of bids, a modification in bidding document in the form of an addendum can be issued in response to a clarification requested by a respective bidder(s) or even whenever the Purchaser considers it beneficial to issue such a clarification and/or amendment to all bidder(s). The clarification/amendment issued (in general) shall be placed on the GIK INSTITUTE web site for the intimation to all the prospective bidder(s).  
Bidder(s) are required to submit their bid(s), which will bear words “CONFIDENTIAL” and for **TENDER NO. GIKI/PD/FME-FEE-989/23** as per Tender Notice.
- 1.4. The Purchaser will not take any responsibility for collecting the bids from any Agency.
- 1.5. The Purchaser reserves the right to increase or decrease the quantities or may cancel any or all items shown in the Schedule of Requirement without assigning any reason thereof.
- 1.6. The Purchaser reserves the right to have the items inspected by its own representative, or by 3<sup>rd</sup> party at its own cost (if required).
- 1.7. It must be indicated in the offer that the Bid fully conforms to Technical Specifications and Terms and Conditions of the Tender.
- 1.8. The Purchaser reserves the right to accept or reject any bid and to annul the bidding process and reject all the bids at any time prior to award of Purchase Order without thereby incurring any liability to the affected bidder(s) or any

obligation there under. However, GIK Institute shall upon request communicate to any bidder(s) who submitted a bid, the grounds for its rejection, but it is not required to justify those grounds.

- 1.9. Unsolicited advice/clarifications and personal approaches by the bidder(s) at any stage of evaluation are strictly prohibited and shall lead to disqualification.
- 1.10. The bidder(s) are expected to examine all instructions, forms, terms and specifications in the Bidding Documents. Failure to furnish all information required by the Bidding Documents or submission of a bid not substantially responsive to Bidding Documents in all respect will result in the rejection of the bid(s).
- 1.11. All prospective bidder(s) are advised to read carefully all terms & conditions mentioned in the Tender Documents prior to filling / submission of their Bid.
- 1.12. Blacklisting procedure of the Company is attached as Appendix-L. The bidders, contractors, suppliers, agents, consultants, partnership or firms shall be dealt with accordingly.
- 1.13. GIK Institute reserves the right to cancel PO/ Order in case of late deliveries.

## 2. **BID PRICES:**

- 2.1. Firm bid prices shall be quoted in Annexure-B duly filled-in, stamped and signed by authorized representative of Bidder(s). Prices must be quoted as per format of Schedule of Requirement (SOR).
- 2.2. Bidding Forms and Bid Summery Sheets from Annexure – “C” to “F” and “H” to “K” must also be duly filled-in, stamped and signed by authorized representative of bidder(s).
- 2.3. Prices must be quoted in Pak Rupees or US Dollar currency (F.O.R Basis only) inclusive of all taxes and duties , indicating unit price and total bid prices. GST must be quoted separately along with copy of GST Certificate only for Pakistani currency. Conditional bid / bid having any price adjustment formula will be rejected.
- 2.4. Prices must be quoted including all charges like handling, loading, transportation and un-loading, Octroi and Zila Tax etc. for delivery of material at Purchaser’s stores located at **required delivery location.**
- 2.5. Quoted prices will be valid for 120 days from the opening date of the **Financial Bid.**
- 2.6. Technical brochure/literature confirming Size, Brand & Country of Origin of quoted items/material must be attached with the Technical Bid (where deemed necessary).
- 2.7. Any Bid not confirming to Clause 2.1 to 2.6 shall be rejected without any right of appeal.
- 2.8. Discount (if any) shall only be entertained on Schedule of Requirement of Bidding Document (Financial Proposal). If the discount is mentioned elsewhere in the bid, the same shall not be entertained.
- 2.9. Tender submitted without Tender Fee Rs 3,000/- (in shape of challan form/ pay order/Demand Draft) & earnest money CDR should be rejected at the time of opening of Tender. Earnest money & challan form will be submitted against each Tender separately.

### **3. BID SECURITY MONEY:**

- 3.1. The sealed bids complete in all respect must reach in the office of Deputy Director Procurement GIK Institute along with Bid Security Money 2% of the total cost in the name of GIK INSTITUTE OF ENGINEERING SCIENCES AND TECHNOLOGY, TOPI in shape of CDR to be attached with financial offer.
- 3.2. Short Bid Security Money or Crossed Cheque as Bid Security Money is not acceptable.
- 3.3. The Bid Security Money of un-successful bidder(s) will be returned after award of Purchase Order to successful bidder(s). The Bid Security Money of successful bidder(s) will be discharged / returned upon bidder(s) furnishing the executing the order/contract (Subject to the satisfactory report without any objection from the end user).
- 3.4. The Bid Security Money of bidder(s) whose bid is rejected under Clause 2.7 will be returned forth-with.
- 3.5. The Bid Security Money shall be forfeited:
  - 3.6.1. If a bidder withdraws its bid during the period of bid validity.
  - 3.6.2. In case of successful bidder, who fails (a) to sign the contract; (b) to furnish performance security (if any).

### **4. SEALING AND MARKING OF BIDS:**

- 4.1. The bidder(s) shall furnish Technical & Financial Bid(s) in two separate sealed envelopes.
- 4.2. Technical Bids will be opened first.
- 4.3. Earnest money as mentioned in Press Tender Notice must be enclosed with Financial Bid.
- 4.4. Only Financial Bid(s) of Technically responsive bidder(s) will be opened publicly.
- 4.5. Financial Bids of technically non responsive bidder(s) will be returned after award of Purchase Order to successful bidder(s).
- 4.6. The bid shall be submitted in a sealed envelope marked as under:



**PROCUREMENT DEPARTMENT**  
**GIK INSTITUTE OF ENGINEERING SCIENCES AND TECHNOLOGY, TOPI**

- 4.7. The envelope shall also bear the word “CONFIDENTIAL” and following identifications:-

**TENDER NO. GIKI/PD/FME-FEE-989/23**

**DON'T OPEN BEFORE (AS PER SCHEDULE MENTIONED IN THE TENDER NOTICE/SOR)**  
**TECHNICAL/FINANCIAL BID(S) (INDICATE ONE ON EACH ENVELOPE)**

- 4.8. If the envelope is not marked, as instructed above, the Purchaser will assume no responsibility for the misplacement or premature opening of bid(s).

**5. DEADLINE FOR SUBMISSION OF BIDS:**

- 5.1. The bids must be delivered at the Procurement Department, GIK Institute, Topi on or before as per schedule mentioned in Press Tender Notice and the same will be opened accordingly.

**6. LATE BIDS:**

- 6.1. Any bid received by the Purchaser after the prescribed deadline for submission of bids mentioned in Press Tender Notice will not be accepted and returned un-opened to the bidder(s).

**7. BID OPENING:**

- 7.1. The purchaser will open the Technical Bid, in the presence of bidder's representative(s) who may choose to attend on date, time and location mentioned above.
- 7.2. The bidder(s) names, bid prices including bid price modification and bid withdrawals, if any, will be announced at the time of financial bid opening.
- 7.3. The Purchaser will examine the bids to determine whether they are complete, no computational errors have been made, the required sureties have been furnished, documents have been properly signed, and the bids are generally in order.
- 7.4. Arithmetical errors found will be corrected as follows:
- 7.4.1. Where there is a discrepancy between amount in figures and word, the amount in word will prevail.
- 7.4.2. Where there is a discrepancy between the unit price and the total amount derive from the multiplication of the unit price and the quantity, the unit price as quoted will govern, unless there is an obvious gross arithmetical error in unit price, in which event, the extended amount quoted would prevail.
- 7.4.3. In case the due date of bids opening falls on a holiday, the bids shall be opened on the next working day.

**8. DETERMINATION OF RESPONSIVENESS:**

- 8.1. After opening of the bids, the purchaser will determine whether each bid is substantially responsive to the requirements of the bidding documents.

- 8.2. For the purpose of this clause, a substantially responsive bid is one which conforms to all the terms and conditions of the bidding documents without material deviation. A material deviation is one which means inconsistent with the bidding document, affects in any substantial way the scope, quality or prescribed delivery schedule or which limits in any substantial way, the Purchaser's right or the bidder's obligation under the contract.
- 8.3. A bid determined to be a non-responsive will be rejected by the purchaser and shall not subsequently be made responsive by the bidder(s) by correction of the non-conformity.
- 8.4. The purchaser may waive any minor deviation non-conformity or irregularity in a bid, which does not constitute a material deviation, provided that the waiver does not prejudice or affect the relative standing order of other bidder(s).
- 8.5. To assist in determining a bid's responsiveness the bidder(s) may be asked for a clarification of his bid. The bidder(s) is not permitted, however, to change bid price or substance of his bid.
- 8.6. The bidder(s) may lodge a written complaint for redress of their grievances and disputes to Dispute Resolution Committee within fifteen days of the placement of the Technical Evaluation report on the web.

#### **9. ISSUANCE OF PURCHASE ORDER (PO):**

- 9.1. The Purchaser will issue Purchase Order to the successful bidder(s) whose bid is determined to be the best evaluated bid.

#### **10. PAYMENT:**

- 10.1 Payment will be made as follows after inspection and acceptance of goods, materials and equipment etc:
  - 10.1.1 Payment after delivery
  - 10.1.2 Advance payment against Bank Guarantee (on a mutual understanding)

#### **11. DELIVERY SCHEDULE:**

- 11.1 Delivery of required material against this tender is to be completed as soon as possible from the date of receipt of confirmed Purchase Order and will provide surety bond/guarantee for provision of delivery within specified period.

#### **12. EXTENSION IN THE DELIVERY PERIOD:**

- 12.1 Delivery of the goods shall be made by the supplier in accordance with the delivery schedule given in Purchase Order.
- 12.2 The supplier may claim extension of the time limits as set forth in the Purchase Order in case of:-
- 12.3 Changes in the specifications of goods, material & equipment by the Purchaser.
- 12.4 Delay in provision of clarifications regarding material, drawings and services by the Purchaser.
- 12.5 Force Majeure pursuant to Clause # 14.
- 12.6 Justified reasons subject to a written request highlighting the same within a period of seven working days prior to expiry of delivery period mentioned in

### Purchase Order.

- 12.7 It should be noted that a request for extension in delivery period shall be considered only if the supplier agrees in writing to pay any increase in taxes or any other charges levied by the Government during the extended delivery period. Purchaser shall not bear any additional price increase during the extended period.
- 12.8 In case of extension in delivery period, the supplier will extend validity of Performance Bond accordingly at his cost.
- 12.9 If the supplier fails to supply the ordered material for any reason, within stipulated time, the Performance Bond shall be forfeited and material shall be purchased from elsewhere at his risk and cost.

### **13. LIQUIDATED DAMAGES:**

- 13.1 If you fail to supply the material in the above specified period, GIK Institute reserves the right to blacklist you for future business or forfeit the security money or impose penalty as per the penalty rates mentioned above of the contract value or may impose any other financial penalty as deemed fit.
- 13.2 Even after imposition of LDs, if the supplier fails to materialize the delivery (material and or services); the Purchaser reserves the right to cancel Purchase order/contract and to forfeit the earnest money (if applicable) after intimating the supplier for such cancellation / forfeiture.

### **14. FORCE MAJEURE:**

- 14.1 The supplier shall not be liable for penalty for delay in delivery of ordered goods, if, and to the extent delay in delivery or other failure to perform his obligation under the Purchase Order, of being the result of occurrence of Force Majeure i.e. causes such as natural calamities, war, civil disturbance, military action, fire as well as other circumstance proved to the satisfaction of the Purchaser to be beyond the reasonable control of the supplier, which may impede the fulfillment of the obligations under the Purchase Order.
- 14.2 The supplier shall notify the Purchaser promptly of the occurrence of Force Majeure and submit his case in writing within 07 days of such occurrence.
- 14.3 If any of the party is prevented to fulfill its assumed obligations by Force Majeure of constant duration of at least one month, the party shall meet for negotiation. If no satisfactory agreement is reached within a period of two months from the Commencement of the Force Majeure conditions, either party shall have the right to cancel the Purchase Order with immediate effect.

### **15. INSPECTION AND TEST:**

- 15.1 The Purchaser's representative(s) shall have the right to inspect and/or test the goods to confirm their conformity with respect to specifications mentioned in the Purchase Order. The representative of Procurement Cell will witness the inspection (where so required).
- 15.2 Should any inspected or tested goods fail to conform to the specifications the purchaser shall reject them and supplier shall replace the rejected goods. All costs incurred on such replacement shall be entirely born by the supplier.
- 15.3 Rejected material shall be moved / replaced by the supplier within 07 days from the receipt of letter/fax issued by the Procurement Department. The

supplier shall be liable for the **storage** charges @ 0.2% (half percent) of the cost of rejected material on every day basis, if the same is not removed within seven days.

- 15.4 Acceptance/rejection of the material by 3rd party (where required) will be final and binding on both the parties.

**16. WARRANTY:**

- 16.1 The supplier shall warrant that all goods supplied under Purchase Order shall be according to specifications given in Purchase Order and approved drawings/design etc. Any deviation in material, drawing/design (where applicable) will be replaced by the supplier at his cost.
- 16.2 The Purchaser shall promptly notify the supplier in writing, of any claims arising under this warranty.
- 16.3 The supplier will invariably provide warranty/guarantee of spare and consumables.

**17. QUALIFICATION OF SELECTED BIDDER(S):**

- 17.1 The Purchaser will determine to its satisfaction whether the bidder(s) selected as having submitted the lowest evaluated, technically responsive bid qualifies to satisfactorily perform the order.
- 17.2 The determination will take into account the bidder(s) financial, technical & production capabilities, availability of items ordered for. The bidder(s) shall provide necessary documents as proof along with the bid.
- 17.3 Any affirmative determination will be a pre-requisite for award of the Purchase Order to the bidder(s). A negative determination will result in rejection of the bid.
- 17.4 The Purchaser reserves the right at the time of award of order to increase or decrease to a reasonable extent in the quantity of goods specified in the Tender Document without any change in price or other terms and conditions.
18. You are encouraged to inform Procurement Department on the following addresses/ contacts, in case where any GIK Institute employee ask for any type of favor whether monetary or in kind:-

<b>DESIGNATION</b>	<b>ADDRESS</b>	<b>TEL #</b>	<b>FAX #</b>	<b>E. MAIL</b>
<b>Deputy Director Procurement</b>	Ghulam Ishaq Khan Institute, Topi.	0938-281026 (Ex: 2213)	0938-281045	<a href="mailto:farid.wahid@giki.edu.pk">farid.wahid@giki.edu.pk</a>

**BIDDING FORM (TECHNICAL BID)**

**Deputy Director Procurement**  
GIK Institute of Engineering Sciences  
and Technology, Topi

Gentlemen,

1. Having examined the Bidding Documents including the specifications, the receipt of which is hereby acknowledged, we the undersigned offer to supply & deliver «Description» in conformity with drawings, specifications of goods and conditions of Tender Document.
2. We undertake if our bid is accepted, to commence delivery within No of days (Please specify days) from the date of receipt of your confirm Purchase Order.
3. If our bid is accepted, we will provide the Performance bank guarantee equal to 10% of the Purchase Order excluding GST, for due performance of the purchase order.
4. We agree to abide by all the terms & conditions of the tender for the period of 120 days from the opening of financial proposal & it shall remain binding upon us and may be accepted at any time before the expiry of that period or any extension thereof agreed by us.
5. Until a formal Purchase Order is placed, this bid, together with your written acceptance thereof, shall constitute a binding contract between us. We understand that you are not bound to accept the lowest priced or any bid you may receive.

Dated this \_\_\_\_\_ day of \_\_\_\_\_ 20\_\_\_\_\_

(Signature) (In  
the capacity of)

Duly authorized to sign Bid for and on behalf of \_\_\_\_\_

(Signature of Witness)

Name: - \_\_\_\_\_

Address: - \_\_\_\_\_

\_\_\_\_\_

**BIDDING FORM (FINANCIAL BID)**

**Deputy Director Procurement**  
GIK Institute of Engineering Sciences  
and Technology, Topi

Gentlemen,

1. Having examined the Bidding Documents including the specifications, the receipt of which is hereby acknowledged, we the undersigned offer to supply & deliver «Description» in conformity with drawings, specifications of goods and conditions of Tender for the sum of Rs. \_\_\_\_\_ (Total bid amount in words) (inclusive of all taxes) or such other sum as may be ascertained in accordance with the said conditions.

2. Until a formal Purchase Order is placed, this bid, together with your written acceptance thereof, shall constitute a binding contract between us. We understand that you are not bound to accept the lowest priced or any bid you may receive.

Dated this \_\_\_\_\_ day of \_\_\_\_\_ 20\_\_\_\_\_

(Signature)  
(In the capacity of)

Duly authorized to sign Bid for and on behalf of \_\_\_\_\_

(Signature of Witness)

Name: - \_\_\_\_\_

Address: - \_\_\_\_\_

\_\_\_\_\_

**BID SUMMARY SHEET**

**TENDER NO. GIKI/PD/FME-FEE-989/23**

**(TO BE ATTACHED WITH TECHNICAL BID)**

1. Bidder Name \_\_\_\_\_  
Address, Phone & Fax No E- \_\_\_\_\_  
mail address \_\_\_\_\_
  
2. Manufacturer Name & Country \_\_\_\_\_  
of Origin: \_\_\_\_\_
  
3. Items Quoted:(give serial no. \_\_\_\_\_  
only): \_\_\_\_\_
  
4. Price Validity: \_\_\_\_\_
  
5. Offered Delivery Period: \_\_\_\_\_
  
6. GST Registration No: \_\_\_\_\_
  
7. Bidding form (Annexure-C attached with Technical bid: Yes ( ) No ( ) \_\_\_\_\_
  
8. Any Deviation: \_\_\_\_\_

Signature

\_\_\_\_\_

Name &

Designation \_\_\_\_\_

**BID SUMMARY SHEET**

**TENDER NO. GIKI/PD/FME-FEE-989/23**

**(TO BE ATTACHED WITH FINANCIAL BID)**

1. Bidder Name \_\_\_\_\_  
Address, Phone & Fax NO. \_\_\_\_\_  
E-mail address \_\_\_\_\_
2. Manufacturer Name & \_\_\_\_\_  
Country of Origin: \_\_\_\_\_
3. Items Quoted:(give serial no. only): \_\_\_\_\_
4. Price Validity: \_\_\_\_\_  
Rs \_\_\_\_\_
5. Total FOR («Deliver To») Price: \_\_\_\_\_  
(Inclusive of all taxes except GST)
6. Total FOR («Deliver To») Price (With  
GST): Rs \_\_\_\_\_
7. Offered Delivery Period: \_\_\_\_\_
8. Payment Terms: \_\_\_\_\_
9. GST Registration No. \_\_\_\_\_
10. Bidding Form (Annexure-C-1 attached with financial bid): Yes No
11. Any Deviation: \_\_\_\_\_

Signature

\_\_\_\_\_

Name &

Designation \_\_\_\_\_



***DECLARATION OF FEES, COMMISSION AND BROKERAGE ETC.  
CERTIFICATE***

Submitted to GIK Institute with the reference to Purchase Order No. \_\_\_\_\_ hereby declares its intention not to obtain or induce the procurement of any contract, right, interest, privileges or other obligation or benefit from Government of Pakistan or any administrative subdivision or agency thereof or any corrupt business practice.

Without limiting the generality of the foregoing, the Seller/ Supplier represents and warrants that it has fully declared the brokerage, commission, fees etc., paid or payable to anyone and not given or agreed to give and shall not be given or agree to give to anyone within or outside Pakistan either directly or indirectly through any national or juridical person, including its affiliate, agent, associate, broker, consultant, briber, finder's fee or kickback, whether described as consultant fee or otherwise, with the object of obtaining or including the procurement of a contract right, interest, privilege or other obligation or benefit in whatsoever form from GOP except that privilege or other obligation or benefit in whatsoever form from GOP except that which has been expressly declared pursuant hereto.

The Seller/ Supplier certifies that it has made and will make full disclosure of all agreement and arrangements with all persons in respect of or related to the transaction with GOP and has not taken any action or will not take any action to circumvent the above declaration, representation or warranty.

The Seller/ Supplier accepts full responsibility and strict liability for making any false declaration not making full disclosure, mis-representing facts or taking any action likely to defeat the purpose of this declaration, representation and warranty. It agrees that any contract, right interest. Privilege or other obligation or benefit obtained or procured as aforesaid shall, without prejudice to any other rights and remedies available to GOP under any law, contract or other instrument, be voidable at the option of GOP.

Notwithstanding any rights and remedies exercised by GOP in this regard, the Seller/ Supplier agrees to indemnify GOP for any loss or damage incurred by it on account of its corrupt business practices and further pay compensation to GOP in an amount equivalent to ten times the sum of any commission, gratification, bribe, finder's fee or kickback given by the Seller/ Supplier as aforesaid for the purpose of obtaining or inducing the procurement of any contract, right, interest, privilege or other obligation or benefit in whatsoever form from GOP.

For & On Behalf of  
Seller/  
Supplier

(WHERE APPLICABLE, TO BE SUBMITTED ON DEMAND OF GIK INSTITUTE)

**FAIR PRICE CERTIFICATE**

WE M/S \_\_\_\_\_ HEREBY CERTIFY THAT PRICES QUOTED BY US AGAINST GIK INSTITUTE TENDER NO. **GIKI/PD/FME-FEE-989/23** ARE THE LOWEST AND MOST COMPETITIVE AS GENERALLY APPLICABLE TO ALL OTHER BUYERS AND OR SOLD THROUGH OUR AGENTS AS PER PREVAILING INTERNATIONAL MARKET AS ON THE DATE OF QUOTE AND IF IT IS ESTABLISHED AT ANY STAGE THAT THESE WERE HIGHER WE SHALL BE HELD RESPONSIBLE AND AGREE TO PAY IMMEDIATELY THE DIFFERENTIAL TO GIK INSTITUTE, TOPI.

SIGNATURE AND SEAL OF THE  
*MANUFACTURER / SOLE AGENT/AUTHORIZED DEALER*

NOTE: FAIR PRICE CERTIFICATE WILL BE REQUIRED, IN CASE SINGLE BID IS FOUND TECHNICALLY RESPONSIVE IN THE RESPECTIVE TENDER.

(On official letter-head of the contractor)  
To be signed by the Chief Executive of the bidding  
company or a representative duly authorized by  
board resolution.

**Integrity and Ethics Undertaking**

We hereby commit and undertake to observe the following principles during our  
participation in the contract execution:

- a) That we will not directly or through any other person or firm, offer, promise or give to any of the employees of GIK INSTITUTE involved in or relevant to the execution of the contract any gain, pecuniary benefit or facilitation payment in order to obtain in exchange any advantage of any kind whatsoever during the execution of contract or at any stage thereafter.
- b) That we did not enter with any bidder into any undisclosed agreement or understanding either formal or informal to restrict competitiveness or to cartelize in the bidding process.
- c) That we will ensure that the remuneration of agents (*if engaged*) is appropriate and for legitimate services only.
- d) That we will not use subcontracts, purchase orders or consulting agreements as means of channeling payments to employees of GIK INSTITUTE.
- e) That we will not and have not committed any offence under the Pakistan Penal Code, Prevention of Corruption Act or National Accountability Ordinance to achieve any advantage, gain or benefit during the tender process or the execution of contract.

We further understand and acknowledge that any violation or transgression of the above mentioned principles will attract disqualification from doing business with GIK INSTITUTE and may also result in permanent exclusion from future contract award processes.

We also accept and undertake to respect and uphold GIK INSTITUTE's absolute right to resort to and impose such disqualification, debarment or exclusion.

For and on behalf of \_\_\_\_\_  
Tender No. \_\_\_\_\_  
Contract No \_\_\_\_\_

*(On official letter-head of the bidder)*

To be signed by the Chief Executive of the bidding company or a representative duly authorized by board resolution.

**Integrity and Ethics Undertaking**

We hereby commit and undertake to observe the following principles during our participation in the tender process and during the contract execution:

- a) That we will not directly or through any other person or firm, offer promise or give to any of the employees of GIK INSTITUTE involved in the tender process or execution of the contract any gain, pecuniary benefit or facilitation payment in order to obtain in exchange any advantage of any kind whatsoever during the tender process or during the execution of contract.
- b) That we have not and will not enter with other bidders into any undisclosed agreement or understanding either formal or informal to restrict competitiveness or to cartelize in the bidding process.
- c) That we will ensure that the remuneration of agents *(if engaged)* is appropriate and for legitimate services only.
- d) That we will not use subcontracts, purchase orders or consulting agreements as means of channeling payments to employees of GIK Institute.
- e) That we will not commit any offence under the Pakistan Penal Code, Prevention of Corruption Act or National Accountability Ordinance to achieve any advantage, gain or benefit during the tender process or the execution of contract.

We further understand and acknowledge that any violation or transgression of the above mentioned principles will attract disqualification from the tender process and may also result in permanent exclusion from future contact award processes.

We also accept and undertake to respect and uphold Institute's absolute right to resort to and impose such disqualification, debarment or exclusion.

For and on behalf of \_\_\_\_\_

Tender No. GIKI/PD/FME-FEE-989/23

Form 4

*Mandatory for participation in Bidding Process*

**A F F I D A V I T**

I, \_\_\_\_\_ S/o \_\_\_\_\_ aged \_\_\_\_\_ years \_\_\_\_\_ working as Proprietor/Managing Partner/Director of M/s \_\_\_\_\_ having its registered office at \_\_\_\_\_ do hereby solemnly affirm and declare on oath as under:

1. That I am competent to swear this affidavit being proprietor/one or the partners/ Director of M/s \_\_\_\_\_
1. That M/s \_\_\_\_\_ is a proprietorship/partnership firm/company is participating in tender process conducted by Institute.
2. That I hereby confirm and declare that none of my/our group/sister concern/associate company is participating/ submitting this tender.
3. That I hereby confirm and declare that my/our firm/company M/s \_\_\_\_\_ and my/our firm/group/company/ sister concern / associate company have not been black listed/de-listed any Institutional agencies/Govt. Deptt/ Public Sector Undertaking.
4. That there is no change in the Name & Style, Constitution and Status of the firm, after Pre-qualification.
5. That I further undertake that in case any of the facts contained above and in-our application is round other-wise or incorrect or false at any stage, my/our firm/company/ group/sister concerns/ associate companies shall stand debarred from the present and future tenders of the GIK INSTITUTE.

(Signature of the Proprietor/ Managing Partner/Director with Seal)

DEPONENT

Verified at \_\_\_\_\_ on \_\_\_\_\_ that the contents of paras 1 to 6 of this affidavit are true and correct to best of my knowledge and no part of this is false and nothing material has been concealed or falsely stated therein.

(Signature of the Proprietor/ Managing Partner/ Director with Seal)

DEPONENT

(Signature & Seal of Notary)

**BLACK LISTING PROCEDURE**

1. **Blacklisting**

Blacklisting means; temporarily or permanently, barring an entity or a person against whom proceedings have been initiated including but not limited to bidder, contractor, supplier, agent, consultant, company, partnership or firm; hereinafter referred to as, Respondent from participating in any future procurement of goods and services. The Respondent(s) individually or collectively as a consortium may stand blacklisted if found to have been involved in any or all of the following acts:

- a) Undermines or adversely affects the operations of the company through any of the following:
  - Withdrawing a bid during the bid validity period;
  - Failure or refusal to:
    - i. sign the Contract;
    - ii. accept Purchase Order / Service Order Terms;
    - iii. execute work;
    - iv. submit 2% earnest money as per tender terms;
    - v. make supplies as per specification agreed;
    - vi. fulfill contractual obligations as per contract;
    - vii. meet purchase order / service order terms and conditions; and/or,
    - viii. to remedy underperformance as per contractual obligations.
    - ix. Or any other non-compliance of obligations vital for the execution / compliance of the contract.
- b) Repeated non-performance.
- c) Indulgences in corrupt or fraudulent practices while obtaining or attempting to obtain contracts in the company.
- d) Convicted of fraud, corruption. tax evasion or criminal misappropriation by a court of competent forum.
- e) Notified blacklisted/debarred/cross debarred by any public sector organization or international agency. In this regards the contractor has to submit a certificate that he or his principal is not declared blacklisted / debarred / cross debarred by any public sector organization or international agency
- f) Furnished information that was false and materially inaccurate or submitted forged or fake documents.

2. **Debarment of Natural Terms.**

The following shall stand disqualified and debarred from participating in GIK INSTITUTE tenders or contracts pursuant to black listing proceedings:

- i. In case of a company; all directors including its Chairman, Chief Executive and Chief Financial Officer.
- ii. In case of partnership; all partners

### 3. Debarment of Associated Companies or Entities

Where a company or an entity has been blacklisted, all its associated or subsidiary undertaking whether by way of common directorship, common management and control, shareholding or direct or indirect control through directors of blacklisted entity etc shall also stand disqualified from participating in GIK INSTITUTE tenders or contracts

### 4. Proceedings for blacklisting

- a) Director Procurement on his own accord or on receipt of information or a complaint shall refer the matter to the Procurement Committee.
- b) The Committee after examining the material placed before it shall determine whether it is necessary and appropriate to initiate formal black listing proceedings.
- c) In case the Committee decides to initiate blacklisting proceedings Respondent shall be formally intimated in writing about the nature of complain/matter and initiation of blacklisting proceedings.
- d) The Respondent shall be intimated by giving a 15 days' notice through courier services, registered post or fax or email and, shall be provided an opportunity of furnishing response either through written representation or personal hearing or both.
- e) In case the Respondent fails to furnish his defense or representation the committee may proceed exparte on the basis of information, record and material available before it provided that two subsequent notices at seven working days intervals have been given.
- f) The Committee shall complete its proceedings within 60 days from the date of first notice given pursuant to paragraph (d) above.
- g) The Respondent against whom blacklisting proceedings have been initiated may be represented through:
  - i. In case of an individual or sole proprietorship; in person.
  - ii. In case of a firm or partnership; by the Chief executive or the Managing Partner, duly authorized.
  - iii. In case of a company; by the Chief Executive or a Director or any officer duly authorized by the Company

### 5. Findings & Decisions:

- a) The Committee after finalizing its proceedings shall record its findings in writing and decide one of the following measures for implementation:
  - i. Temporarily debarred, specifying the time period;
  - ii. Blacklisted if the Respondent fails to take remedial action within the specified time; or,
  - iii. Blacklisted.
- b) The order of the Committee shall be communicated in writing as per Form 3.
- c) The documents, deliberations reduced in writing and all records of

proceedings are to be maintained for five years by the Procurement Cell

6. Appeal

- a) The Respondent may appeal within 15 days working days of intimation of decision of the Committee to the Pro-Rector (Admin & Fin) in writing of any irregularity in the decision of the Committee.
- b) If there exists any substance in the appeal the Pro-Rector (Admin & Fin) after recorded reasons may direct that Committee may review the case by providing opportunity of hearing to the Respondent provided that the review shall be completed within 30 days.
- c) The Committee shall record its findings in writing and refer the same to the Pro-Rector (Admin & Fin) for appropriate orders.

Deputy Director Procurement  
GIK Institute, Topi